

RKDN: 2 – and 3-way ball valves with female thread, PN 40

Areas of application

Control ball valve for continuous control of cold water, hot water or air in closed networks ¹⁾. Water quality as per VDI 2035, the use of strainers is recommended. Together with actuators from the type BVA and DAF as regulating unit.

Features

- Nominal pressure 40 bar ³⁾
- Nominal diameter DN15 to DN50
- Equal percentage ball valve characteristic, integrated directly into ball
- Characteristic can be set to linear or quadratic with UT rotary drive
- Spindle with large sliding surface and Teflon glide ring
- High control ratio of 500:1
- Low torque thanks to collar with O-ring bearing

Technical description

- Ball valve with female thread as per ISO 7/1 Rp or NPT
- Body made of DZR (dezincification resistant) cast brass
- Axle made of DZR brass
- Ball made of DZR brass, chrome-plated and polished surface
- Axle seal with double O-ring made of EPDM
- Strainer and screw fitting available as accessories



T10647



T10648

Overview of Types 2 - and 3-way ball valves

Type	Nominal size DN	Connection ISO 7/1 IG	kvs-value m ³ /h	Weight kg	Type	Nominal size DN	Connection ISO 7/1 IG	kvs-value m ³ /h	Weight kg
RKDN15/2/1	15	IG 1/2"	1	0,29	RKDN15/3/1,6	15	IG 1/2"	1,6	0,31
RKDN15/2/1,6	15	IG 1/2"	1,6	0,29	RKDN15/3/2,5	15	IG 1/2"	2,5	0,31
RKDN15/2/2,5	15	IG 1/2"	2,5	0,29	RKDN15/3/4	15	IG 1/2"	4	0,31
RKDN15/2/4	15	IG 1/2"	4	0,29	RKDN15/3/6,3	15	IG 1/2"	6,3	0,33
RKDN15/2/6,3	15	IG 1/2"	6,3	0,29	RKDN20/3/4	20	IG 3/4"	4	0,4
RKDN15/2/10	15	IG 1/2"	10	0,29	RKDN20/3/6,3	20	IG 3/4"	6,3	0,4
RKDN20/2/4	20	IG 3/4"	4	0,32	RKDN25/3/10	25	IG 1"	10	0,49
RKDN20/2/6,3	20	IG 3/4"	6,3	0,32	RKDN32/3/16	32	IG 1 1/4"	16	0,73
RKDN20/2/10	20	IG 3/4"	10	0,32	RKDN40/3/25	40	IG 1 1/2"	25	1,10
RKDN25/2/6,3	25	IG 1"	6,3	0,49	RKDN50/3/40	50	IG 2"	40	1,76
RKDN25/2/10	25	IG 1"	10	0,49					
RKDN25/2/16	25	IG 1"	16	0,49					
RKDN32/2/10	32	IG 1 1/4"	10	0,73					
RKDN32/2/16	32	IG 1 1/4"	16	0,73					
RKDN32/2/25	32	IG 1 1/4"	25	0,73					
RKDN40/2/16	40	IG 1 1/2"	16	1,10					
RKDN40/2/25	40	IG 1 1/2"	25	1,10					
RKDN40/2/40	40	IG 1 1/2"	40	1,10					
RKDN50/2/25	50	IG 2"	25	1,76					
RKDN50/2/40	50	IG 2"	40	1,76					
RKDN50/2/63	50	IG 2"	63	1,76					

Operating temperature ²⁾	-10...130 °C
Operating pressure	-10...50 °C 40 bar +130 °C 35 bar
Valve characteristic	gleichprozentig
Range ability with actuator	> 50:1 (typical)
Leakage rate	0,001% of kvs value
Rotation angle	90 °

- 1) See engineering and fitting notes for open circuits
 2) No stuffing box heater required at temperature of less than 0 °C
 3) For air, low-pressure steam: DN40 - PN25, DN50 - PN20

Operating temperature ²⁾	-10...130 °C
Operating pressure	-10...50 °C 40 bar +130 °C 35 bar
Valve characteristic	gleichprozentig
Range ability with actuator	> 50:1 (typical)
Leakage rate	0,001% of kvs value
Rotation angle	90 °

- 1) See engineering and fitting notes for open circuits
 2) No stuffing box heater required at temperature of less than 0 °C.
 3) For air, low-pressure steam: DN40 - PN25, DN50 - PN20

Combination RKDN with electric rotary actuators

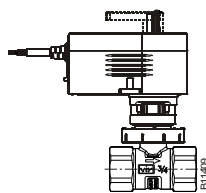

Actuator Running time: Eingang:				FBVA 5.2 30s 2-/3-Punkt				BVA 10.1/2 120s 2-/3-Punkt	BVA 10.1M 35 / 60 / 120 s 2-/3-Punkt / 0...10 V
	Against pressure				Against pressure				
Ball valve	Δp_{max}	Δp_s	close/off pressure		Δp_{max}	Δp_s	close/off pressure		
RKDN15	1,8	–	–		3,5	–	–		
RKDN20	1,8	–	–		3,5	–	–		
RKDN25	1,8	–	–		3,5	–	–		
RKDN32	1,2	–	–		2,4	–	–		
RKDN40	1,2	–	–		2,4	–	–		
RKDN50	1,2	–	–		2,4	–	–		

Δp_{max} [bar]

Maximum permissible pressure difference across the valve at which the drive can still reliably open and close the valve taking Δp_v into consideration.

Δp_s [bar]

Maximum permissible pressure difference across the valve in the event of a problem (pipeline break downstream of valve) at which the drive can reliably close with "fast" stroke passage

close/off
pressure

Maximum possible pressure difference across the valve during control operation at which the drive can still open and close the valve. A shorter service life can be expected if this method is used. Cavitation, erosion and pressure surges can damage the valve. The values only apply to the assembled combination of the valve fitted to the drive.

Function

The control ball valve can be controlled to any intermediate position using an electric drive. Closing against the operating pressure is possible with the BVA actuators or the valve actuators with spring return DAF, and closing with the operating pressure is not permitted.

Closing against the pressure



Description

These control ball valves are characterised by being extremely reliable and accurate, and make a considerable contribution to providing environmentally friendly control. They comply with the most demanding requirements such as a quick-closing function, coping with differential pressures, controlling media temperatures and providing a shut-off facility – all with a low-noise design.

The spindle of the ball valve is automatically connected to the axle carrier of the drive. The brass ball regulates an equal-percentage flow in the control branch. The tightness of the ball is safeguarded by the Teflon collar that is inserted into the body. An EPDM O-ring is inserted behind these two collars. These O-rings permit the ball and both collars to make a small axial movement that provides an extremely good seal and generates little torque.

The tightness of the spindle is safeguarded by 2 O-rings that cannot be replaced if leakage occurs.

Engineering and fitting notes

The valves are combined with the rotary actuators with or without spring return. The actuator is directly attached to the ball valve and held in place by a bayonet connection. The drive axle is connected to the spindle automatically, for which purpose the axle of the ball valve must be in an intermediate position. During the commissioning of the system the UT actuators moves to the open position and both devices are connected automatically. The rotation angle of the ball valve is also detected by the actuator, meaning that no other settings are required. The characteristic curve of the UT drives can be set to linear or quadratic. In order to prevent the ball valve from blocking in the final position, the UT actuator makes a rotation angle movement of approx. 30° if the output signal has not changed at the final positions for about 3 days.

In order to prevent impurities from being retained in the water (e.g. welding beads, rust particles etc.) and damaging the PTFE collar, strainers must be installed on each floor or in each feed pipe. For strainers see accessories, pay attention to usage and temperature range for each model. For water requirements see VDI 2035.

All ball valves must only be used in closed circuits. Excessive oxygen content in open circuits can destroy the valve. In order to prevent this, an oxygen binding material must be used; the manufacturer of the solution must be consulted with regard to compatibility in order to prevent corrosion. The material list can be used for this purpose.

The fittings are usually insulated in the systems. Care must be taken not to insulate the flange that holds the drive when doing this.

In order to prevent disturbing flow noise in quiet rooms, the pressure difference across the valve must not exceed 50% of the specified values.

The crank handle is fixed to the actuator. In order to operate the crank handle the manual adjustment knob on the actuator must be pushed downwards. The actuator will not operate until this knob is moved back to the upper position. There is also a square on the crank handle that matches the square of the ball valve spindle..

Use with water

When water is being used that has been mixed with glycol or inhibitor, compatibility with the materials and seals in the valve should be clarified with the manufacturer for safety reasons. The table of materials shown below can be used for this purpose. We recommend using a concentration of between 20% and 50% when glycol is being used.

The valves are not suitable for use in potentially explosive areas. The materials that have been selected are approved for use with drinking water. The entire valve as a unit is not certified for use with drinking water.

Installation position

The final control element can be installed in any position, but a suspended installation position is not recommended. Condensation and dripping water must be prevented from penetrating the actuator.

Additional technical data

Technical Information

Pressure and temperature specifications	EN 764, EN 1333
Fluidic parameters	EN 60534 Page 3
Technical handbook "Actuators"	7 000477 003
Parameters, installation instructions, control, general	Applicable EN, DIN instructions
Pressurised equipment CE conformity directive, no CE symbol (fluid group II)	97/23/EC Clause 3.3

Additional design specifications

The body of the ball valve is made from DZR hot-pressed brass (EN 12165) with cylindrical female thread in acc. with ISO 7/1 Rp. Axle seal with double ethylene propylene O-ring.

DIN material numbers

	DIN material number	DIN designation
Body of ball valve	CW602N	CuZn36Pb2As
Connector	CW602N	CuZn36Pb2As
Ball, polished, chrome plated	CW602N	CuZn36Pb2As
Axle	CW602N	CuZn36Pb2As
O-Ring	EPDM	
Collar	PTFE	

Supplementary information concerning pressure difference definitions

Δp_v :

Max. permitted pressure difference across the valve for each stroke position, restricted by noise level and erosion.

This parameter specifically characterises the hydraulic behaviour of the valve as an element that is flowed through. The service life and usability of the valve is improved by monitoring cavitation and erosion and the associated noise generation.

Δp_{max} :

Maximum permitted pressure difference across the valve at which the actuator can open and close reliably.

The following are taken into consideration: static pressure and fluidic influences. Problem-free stroke passage and tightness are guaranteed with this value. However, the value must not be less than the Δp_v value for the valve.

Δp_s :

Max. permitted pressure difference across the valve in the event of a problem (e.g. power failure, excessive temperature or pressure, pipe break) at which the actuator can close and seal the valve and maintain the entire operating pressure against atmospheric pressure if necessary. Since this is a quick-closing function with "fast" stroke passage, Δp_s can be greater than Δp_{max} or Δp_v . The interfering fluidic effects that occur in this case are quickly run through and are of lesser importance when this method is being used.

The values only apply to the control load in three-way valves.

Δp_{stat} :

Line pressure downstream of the valve. Essentially corresponds to the dead pressure with the pump switched off, e.g. caused by the height of the liquid in the system, pressure increased caused by pressure tanks, steam pressure etc.

The static pressure of valves that close with pressure must be added to the pump pressure before use.

Dimension drawings

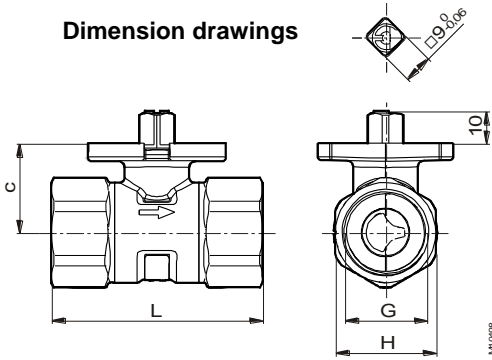

DN	c mm	G	L mm	H mm
15	27,6	Rp ½	61,6	26
20	27,6	Rp ¾	67,4	31
25	30,5	Rp 1	76,8	39
32	34,3	Rp 1¼	88,0	48
40	39,8	Rp 1½	101,8	55
50	52,8	Rp 2	116,2	67

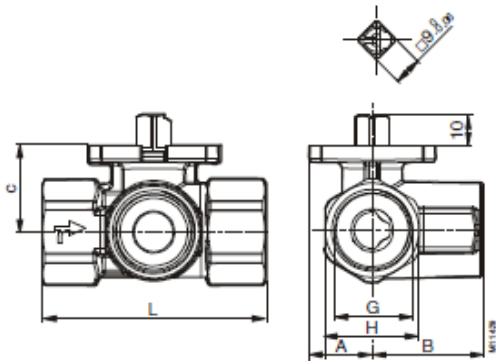

DN	A mm	B mm	c mm	L mm	L mm	G	H mm
15	21	34	24 (28)*	67	67	Rp ½	26
20	21	37	28	72	72	Rp ¾	31
25	21	45	31	85	85	Rp 1	39
32	24	53	34	99	99	Rp 1¼	48
40	28	57	40	110	110	Rp 1½	55
50	34	69	53	131	131	Rp 2	67

**Combination
BVA 5/10**

